



# Industrial Burners

Greater safety, reliability and energy efficiency



Click to begin



# Need to ensure safety, improve energy efficiency, reduce operating costs and mitigate downtime?



Outdated, inferior combustion systems cause difficult installations, demand constant maintenance and are inefficient with natural resources.

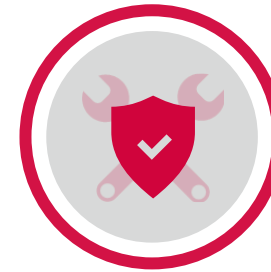

[▶ Click for more](#)



[▶ Click for more](#)



[▶ Click for more](#)

For industries such as oil and gas, metallurgy, construction, food and beverage and hospital HVAC, there is high demand for superior combustion solutions that offer safety, reliability and energy efficiency.

Fuel train installers must procure instruments and controls which enable the user to meet safety and energy efficiency standards, while ensuring reliability and optimizing operational cost and performance. OEMs, distributors, contractors and end-users face challenges in acquiring customized plug and play solutions from a single source supplier.

Total cost-of-ownership is also affected by high maintenance frequency, installation time and labor-intensive steps.



# Need to ensure safety, improve energy efficiency, reduce operating costs and mitigate downtime?



Outdated, inferior combustion systems cause difficult installations, demand constant maintenance and are inefficient with natural resources.



Debris could damage fuel train devices and burner. Up to 20% annual heating cost savings if safety shut-off and control valves are properly maintained.

— ASCO industry research and guidelines

For industries such as oil and gas, metallurgy, construction, food and beverage and hospital HVAC, there is high demand for superior combustion solutions that offer safety, reliability and energy efficiency.

Fuel train installers must procure instruments and controls which enable the user to meet safety and energy efficiency standards, while ensuring reliability and optimizing operational cost and performance. OEMs, distributors, contractors and end-users face challenges in acquiring customized plug and play solutions from a single source supplier.

Total cost-of-ownership is also affected by high maintenance frequency, installation time and labor-intensive steps.



# Need to ensure safety, improve energy efficiency, reduce operating costs and mitigate downtime?



Outdated, inferior combustion systems cause difficult installations, demand constant maintenance and are inefficient with natural resources.



A burner consumes large quantities of fuel, whose price has been rising at an increasing rate since 1999. Even modest gains in overall efficiency can yield significant savings.

— Power Flame Inc. 2005

For industries such as oil and gas, metallurgy, construction, food and beverage and hospital HVAC, there is high demand for superior combustion solutions that offer safety, reliability and energy efficiency.

Fuel train installers must procure instruments and controls which enable the user to meet safety and energy efficiency standards, while ensuring reliability and optimizing operational cost and performance. OEMs, distributors, contractors and end-users face challenges in acquiring customized plug and play solutions from a single source supplier.

Total cost-of-ownership is also affected by high maintenance frequency, installation time and labor-intensive steps.



# Need to ensure safety, improve energy efficiency, reduce operating costs and mitigate downtime?



Outdated, inferior combustion systems cause difficult installations, demand constant maintenance and are inefficient with natural resources.



Boiler efficiency and energy/fuel consumption can account for a large portion of a plant's utility cost. Measures to improve boiler efficiency can bring about a significant improvement in your bottom line.

— Lathrop Trotter 2017

For industries such as oil and gas, metallurgy, construction, food and beverage and hospital HVAC, there is high demand for superior combustion solutions that offer safety, reliability and energy efficiency.

Fuel train installers must procure instruments and controls which enable the user to meet safety and energy efficiency standards, while ensuring reliability and optimizing operational cost and performance. OEMs, distributors, contractors and end-users face challenges in acquiring customized plug and play solutions from a single source supplier.

Total cost-of-ownership is also affected by high maintenance frequency, installation time and labor-intensive steps.



# Increase safety and reliability, with precise flow control and greater energy efficiency.

A reliable, energy efficient system with reduced operational costs is a common goal across the worldwide industrial burner market – more precise pressure and flow control, express delivery, lower installation costs and easy installation/maintenance.

As the global leader of gas train solutions, Emerson understands this. That's why we continue to demonstrate a commitment to this industry, offering you a complete solution, with global safety approvals, increased reliability, flow performance and easy-to-install field devices.

“Emerson’s Industrial Energy team helped overall boiler efficiency with up to a double-digit reduction in fuel usage and a significant drop in carbon levels in the ash. The boiler also operated more reliably.”  
— Engineering and operations teams, a multinational sugar mill



Operate with safety and reliability in mind, with robust and durable products



Improve energy efficiency



Improve burner heat output



Externalize the fuel train design



# Increase safety and reliability, with precise flow control and greater energy efficiency.

A reliable, energy efficient system with reduced operational costs is a common goal across the worldwide industrial burner market – more precise pressure and flow control, express delivery, lower installation costs and easy installation/maintenance.

As the global leader of gas train solutions, Emerson understands this. That's why we continue to demonstrate a commitment to this industry, offering you a complete solution, with global safety approvals, increased reliability, flow performance and easy-to-install field devices.

“Emerson’s Industrial Energy team helped overall boiler efficiency with up to a double-digit reduction in fuel usage and a significant drop in carbon levels in the ash. The boiler also operated more reliably.”  
— Engineering and operations teams, a multinational sugar mill



Operate with safety and reliability in mind, with robust and durable products



- Meet global industry standards and regulations – spanning UL, CSA, Factory Mutual, RoHs, CE and IEC
- Enable operations to run in the most demanding scenarios with low source pressure, in frigid temperatures, minimal power supply and for remote and hazardous locations
- Routinely test with easy to access pressure taps
- Reduce the risk of warranty repairs and maintenance calls



# Increase safety and reliability, with precise flow control and greater energy efficiency.

A reliable, energy efficient system with reduced operational costs is a common goal across the worldwide industrial burner market – more precise pressure and flow control, express delivery, lower installation costs and easy installation/maintenance.

As the global leader of gas train solutions, Emerson understands this. That's why we continue to demonstrate a commitment to this industry, offering you a complete solution, with global safety approvals, increased reliability, flow performance and easy-to-install field devices.

“Emerson’s Industrial Energy team helped overall boiler efficiency with up to a double-digit reduction in fuel usage and a significant drop in carbon levels in the ash. The boiler also operated more reliably.”  
— Engineering and operations teams, a multinational sugar mill



Improve energy efficiency



X

- Go from a linkage or parallel air/fuel ratio control to a fully metered best in class control system
- Take a step further in Nox and CO emissions reduction
- Reduce fuel consumption



# Increase safety and reliability, with precise flow control and greater energy efficiency.

A reliable, energy efficient system with reduced operational costs is a common goal across the worldwide industrial burner market – more precise pressure and flow control, express delivery, lower installation costs and easy installation/maintenance.

As the global leader of gas train solutions, Emerson understands this. That's why we continue to demonstrate a commitment to this industry, offering you a complete solution, with global safety approvals, increased reliability, flow performance and easy-to-install field devices.

“Emerson’s Industrial Energy team helped overall boiler efficiency with up to a double-digit reduction in fuel usage and a significant drop in carbon levels in the ash. The boiler also operated more reliably.”  
— Engineering and operations teams, a multinational sugar mill



Improve burner heat output



- Gain power in your process by choosing best in class high flow fuel train equipment
- Avoid downtime in case of high demand by ensuring low pressure drop before the burner



# Increase safety and reliability, with precise flow control and greater energy efficiency.

A reliable, energy efficient system with reduced operational costs is a common goal across the worldwide industrial burner market – more precise pressure and flow control, express delivery, lower installation costs and easy installation/maintenance.

As the global leader of gas train solutions, Emerson understands this. That's why we continue to demonstrate a commitment to this industry, offering you a complete solution, with global safety approvals, increased reliability, flow performance and easy-to-install field devices.

“Emerson’s Industrial Energy team helped overall boiler efficiency with up to a double-digit reduction in fuel usage and a significant drop in carbon levels in the ash. The boiler also operated more reliably.”  
— Engineering and operations teams, a multinational sugar mill



Externalize the fuel train design



X

- Plug and Play ready to use fuel train from a single supplier
- Faster installation and commissioning



# Emerson can help you overcome your reliability issues with a complete industrial burner solution

Emerson can supply solutions for your entire gas network, from distribution to burner's fuel train. These solutions comply with local safety standards and best practices. Our broad portfolio allows us to offer a flexible plug and play high performances fuel train solution.

Learn More

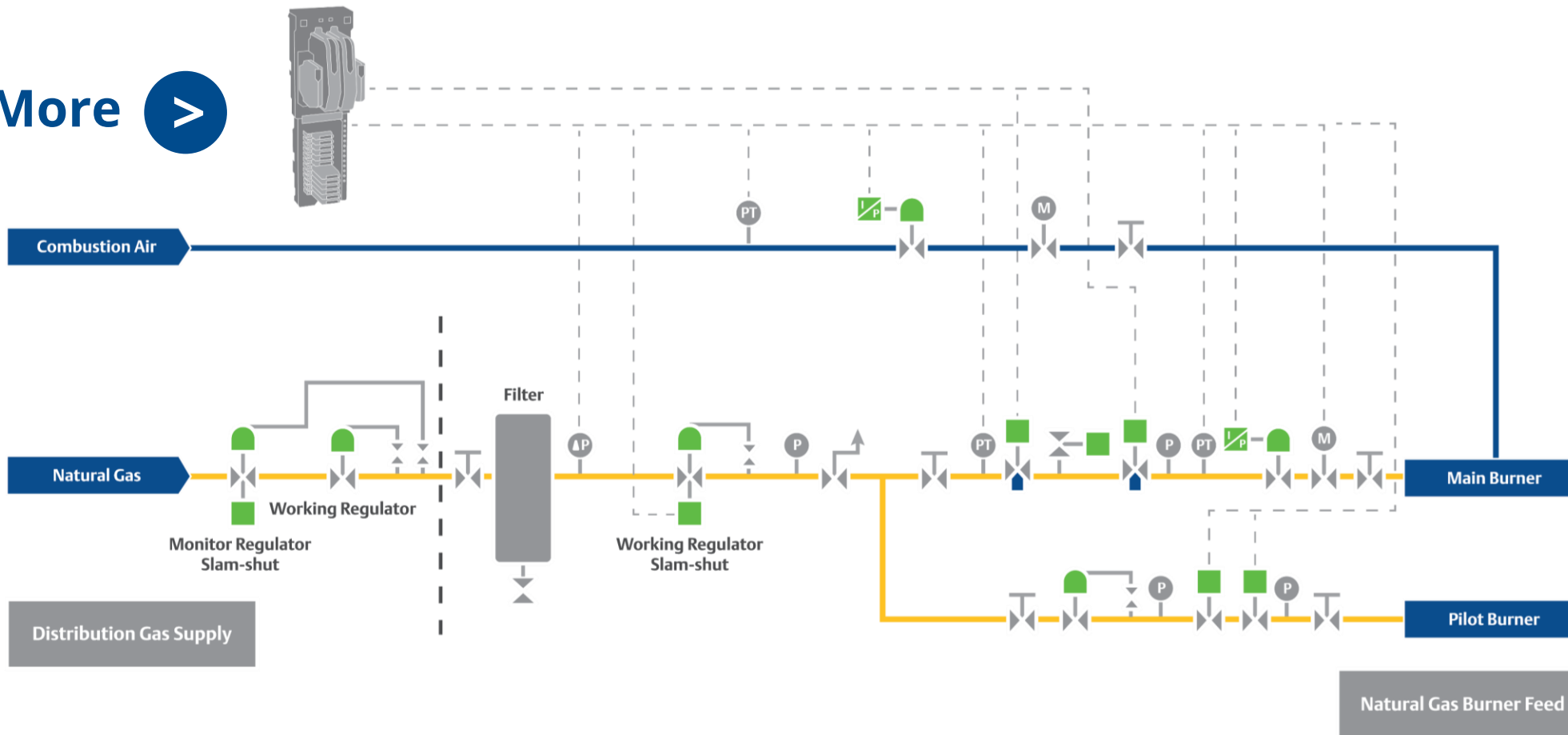
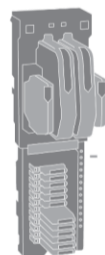

Safety Shut-Off

Pressure and Flow Control

Control, Measurement and Instrumentation

Complete Skid Solutions



# Emerson can help you overcome your reliability issues with a complete industrial burner solution

## Safety Shut-Off

Fuel shut-off in pipe trains and gas systems is a safety measure required by industry standards and regulatory bodies such as UL, CSA, FM, CE, ASME, NFPA. The range of ASCO solenoid and motorized combustion valves meets global safety requirements and offers high performance in flow and pressure.

[Learn More](#) >

## Pressure and Flow Control

Managing pressure and flow is critical in combustion processes and fuel trains. The control of pressure will allow users to meet the required demand of heat needed for heating equipment and unit operation. Air-to-fuel ratio and modulating flow control are adjustable through an entire range of pneumatic and electrically motorized ball, butterfly globe and angle seat control valves.

[Learn More](#) >

## Control, Measurement and Instrumentation

Connectivity is achieved through Emerson's DeltaV™ distributed control systems (DCS). Burner management and entire start-up and shut-down sequences for fuel trains are executed through these controllers.

[Learn More](#) >

## Complete Skid Solutions

Complete skid packages are ideal for compact, plug and play solutions. These systems are designed to provide reliable combustion solutions that offer safety, reliability and energy efficiency.

[Learn More](#) >



# Fuel Safety Shut-Off Valves

Known for reliability and performance, Emerson offers an extensive range of ASCO™ safety shut-off valves for safe commercial and industrial burner shut-off. The ASCO product range consists of solenoid, pneumatic and motorized automatic safety shut-off valves. It also contains vent and pilot valves for multiple media (fuel gas and fuel oil), along with specialty solenoid valves for low temperature, compact and commercial applications. The broad range of ASCO Fuel Safety Shut-Off Valves for burners covers a broad range of application with pipe sizes from 1/8 / DN6 to 6 in. / DN150 in different regions with certifications such as FM 7400, UL429, CSA/ANSI Z21.21 C/I • CSA 6.5 C/I, EN161 and EN 16678.

**What's your opportunity?**



**Services offered**



**Featured products**



# Fuel Safety Shut-Off Valves - What's your opportunity?

- Optimize on/off control with modular valve bodies that mount in any position
- Increase the performance of your entire combustion system with compact footprints and mono block options
- Simplify maintenance with flow optimized disks that provide the maximum application flow



# Fuel Safety Shut-Off Valves - Services offered

- An extensive distribution channel network that reaches around the globe
- A global express program with many
- ASCO products' SKUs having same-day / 5-day delivery
- Extensive product portfolio helps minimize the number of vendors managed

**When you need to increase production efficiency and reduce downtime, Emerson has got you covered – for your complete combustion system.**

ASCO valves are synonymous with safety and our valves and actuators used for combustion systems are no exception. From the opportunity for routine testing with upstream and downstream pipe taps, to the improvement in flow, ASCO products are known to decrease in maintenance cycles. Improve your control and efficiency, all while enhancing product quality and throughput. Emerson has been providing solutions in this market for over 20 years and now with the advent of global approvals we can continue to lead the industry in safety.



# Fuel Safety Shut-Off Valves - Featured products



**ASCO™ Series 158 and 159  
Gas Safety Shut-Off Valve**



**ASCO Series H117/H118/H137  
Gas Safety Shut-Off Valve**



**ASCO Series 215 and 040  
Gas Safety Shut-Off Valve**



**ASCO Series 290D  
Gas Safety Shut-Off Valve**



**ASCO Series 214  
Gas Safety Shut-Off Valve**

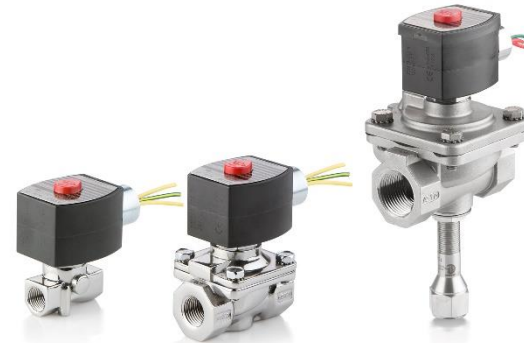

**ASCO Series HV  
Gas Safety Shut-Off Valve**



**ASCO Series HOV  
Oil Safety Shut-Off Valve**



**ASCO Fuel Oil  
Solenoid Valves**

# Fuel Safety Shut-Off Valves - Featured products

## ASCO™ Series 158 and 159 Gas Safety Shut-Off Valve



Combustion safety shut-off valve that increases safety and reliability and enhances higher heat output.

- Designed specifically for burner-boiler applications
- High flow rate creates highest BTU (kW) rating in the industry
- Double valve monobloc design simplifies installation
- Broadest ambient temperature rating of the market from -40°C / -40°F to 66°C / 150°F
- FM, UL, CSA and EN161 certified

[Learn more >](#)



# Fuel Safety Shut-Off Valves - Featured products

## ASCO™ Series H117/H118/H137 Gas Safety Shut-Off Valve



Hydramotor® operated safety shut-off/control gas valves used for commercial and industrial burner applications.

- Rugged construction cast iron valve provides high flow and higher-pressure tolerance
- Watertight and explosion-proof enclosures
- Broad temperature tolerance -40°C / -40°F to 66°C / 150°F
- Broad range of sizes from 3/4 / DN20 to 6 in. / DN150
- Slow opening and fast closing design
- FM, UL and CSA certified

[Learn more >](#)



# Fuel Safety Shut-Off Valves - Featured products

## ASCO™ Series 215 and 040 Gas Safety Shut-Off Valve

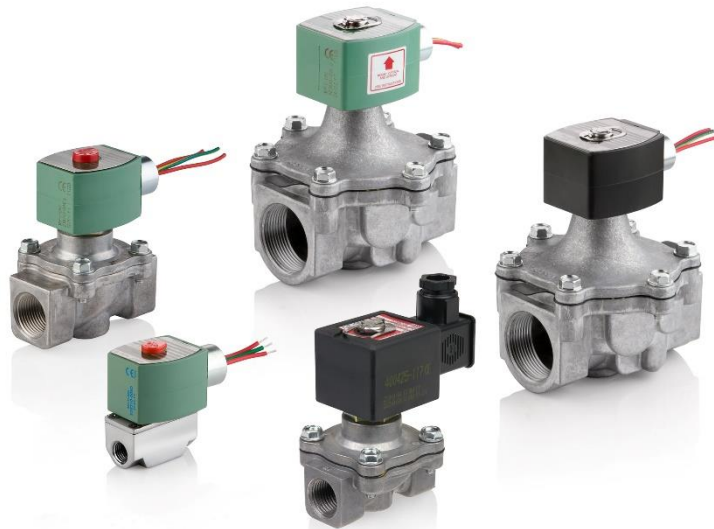

Lightweight aluminum solenoid valves for a broad variety of industrial and commercial burners and gas applications.

- Broad range of size 1/8 / DN6 to 3 in. / DN80
- Optional explosion proof coil
- Compact and high flow designs
- Provided with 1/8 in. / DN6 threaded upstream and downstream pipe taps with plugs for routine testing
- FM, UL, CSA + few EN161 models certified

[Series 215 >](#)

[Series 040 >](#)

# Fuel Safety Shut-Off Valves - Featured products

## ASCO™ Series 290D Gas Safety Shut-Off Valve



Angle body shut-off valve for gas fuel burners typically used within glass, steel and metal production and industrial boilers or furnaces.

- Angled seat design provides high flow capacity, high pressure capability up to 9 bar / 130 psi
- Fast and repeatable closing times, long service life (tested for millions of cycles)
- EN161 certified for use with fuel gas, suitable for harsh environments, oxygen and other complex media such as coke oven gas

[Learn more >](#)

# Fuel Safety Shut-Off Valves - Featured products

## ASCO™ Series 214 Gas Safety Shut-Off Valve



Lightweight aluminum solenoid valves for a high flow, low temperature and low-pressure applications.

- Broad range of size 3/4 / DN20 to 3 in. / DN80
- Broad temperature rating -40°C / -40°F to 60°C / 140°F
- Optional explosion proof coil
- Designed with mounting flanged for easy installation / replacement
- Provided with 1/8 in. / DN6 threaded pipe taps with plugs for routine testing
- FM, UL, CSA certified

[Learn more >](#)

# Fuel Safety Shut-Off Valves - Featured products

## ASCO™ Series HV Gas Safety Shut-Off Valve

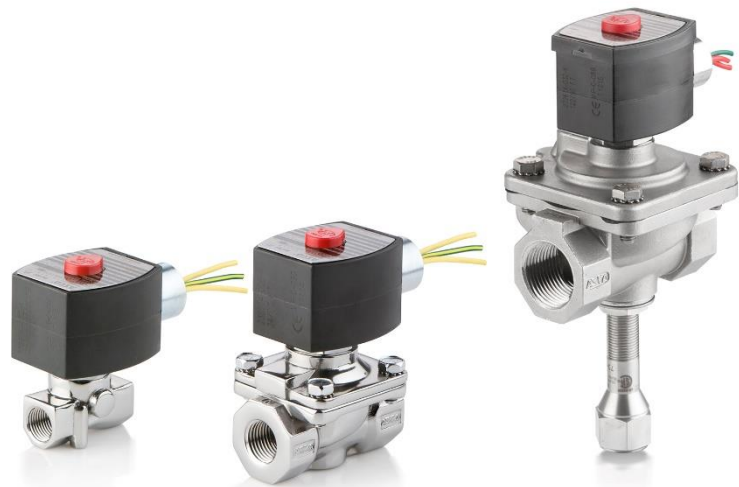

Low-temperature stainless steel solenoid-actuated fuel gas shut-off valves for commercial and industrial gas burners in harsh environments.

- Explosion proof coil
- Optional low power peak and hold technology
- Low temperature up to -40°C / -40°F
- Specific configuration for LPG gas in gas and liquid state
- Meets the metallurgical requirements of NACE MR-0175
- CSA certified

[Learn more >](#)

# Fuel Safety Shut-Off Valves - Featured products

## ASCO™ Series HOV Oil Safety Shut-Off Valve



Two- and three-way Hydramotor® operated safety shut-off valves that provide reliable on-off control of fuel oil.

- Flexible two-piece actuator and body design
- Broad ambient temperature range from -40°C / -40°F to 66°C / 150°F
- Flexible field mounting allows installation in any orientation

[Learn more >](#)

# Fuel Safety Shut-Off Valves - Featured products

## ASCO™ Fuel Oil Solenoid Valves



2 or 3-way solenoid valves allows safe shut-off and oil recirculation in commercial and industrial oil burners.

- Oil safety shut-off valve for fuel oil up to 1500 SSU
- Fuel oil #2, #4, #5 and heated #6
- Fuel oil temperature up to 130°C / 267°F

[Learn more >](#)

# Pressure Regulation and Precise Flow Control

Precise gas flow is essential to maintaining stoichiometric balance and optimizing fuel usage. This is delivered through ball, globe, butterfly and angle body seat valves actuated through a range of operators, motors and drives. The ASCO™ Series 290 valve, Fisher™ easy-e™ Type Globe Control valve and the Fisher Vee-Ball control valve are reliable products which enable customers to meet precise control of air, oxygen, butane, propane and other fuels. Fuel gas regulators with integral overpressure protection are positioned upstream of the safety shut-off valves. Emerson's regulators are utilized through a variety of industrial and district heating applications to deliver consistent, reliable pressure.

**What's your opportunity?**



**Services offered**



**Featured products**



# Pressure Regulation and Precise Flow Control - What's your opportunity?

- Accurately control the amount of gas and air going to the burner
- Lower costs of materials and installation with precise control over your system
- Utilize products with compact footprints for tight space applications
- Maintain boiler efficiency and reduce downtime with advisory diagnostics and optimal accuracy



# Pressure Regulation and Precise Flow Control - Services offered

- Custom process control software to make sure we are the right fit for your process
- Integrated enclosure solutions – dedicated teams to help design, develop and deliver integrated solutions

**Let Emerson help you ensure safety while maximizing fuel usage for your combustion system applications.**

Increasing your cost savings by reducing fuel waste and system downtime for unscheduled maintenance is paramount to continued success. Emerson can provide you with a single point of responsibility for products, documentation and support. All of our products and solutions meet rigorous certifications and standards. For more information regarding specific product certifications for your region, our experts can help. Let's connect.



# Pressure Regulation and Precise Flow Control - Featured products



**Fisher™ Type VS100 and OSE  
Stand alone Slam-Shut Device**



**Fisher 133, LSR, Tartarini™ M Large  
Direct-Operated Pressure Reducing Regulators**



**Fisher Vee-Ball™ Valve with DVC6200 Digital Valve  
Controller and Fisher easy-e™ ET Globe Valve with  
C1 Valve Controller and easy-e Trim Cartridge**



**Bettis™ SCE300  
Electric Actuator**

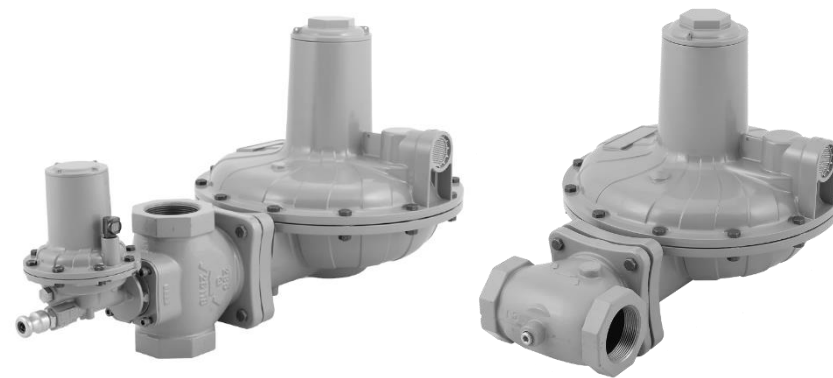

**Fisher Commercial Service Pressure Reducing  
Regulators with Overpressure Protection**



**Fisher Type 1098-EGR, EZL, 299H and 99  
Pilot Operated Pressure Reducing Regulators**

# Pressure Regulation and Precise Flow Control - Featured products

## Fisher™ Type VS100 and OSE Stand alone Slam-Shut Device



Stand-alone Fisher. slam-shuts offer complete shut-off service without external power supply. Instantaneous shut-off keeps the downstream system from seeing emergency pressure levels.

- Slam-shut protection shuts-off the gas supply if there is an upset condition, maintaining safe pressure without emissions
- Over and under pressure set points will protect against multiple failure types such as line break or disconnected control line
- OSE slam-shut incorporates a two stage tripping mechanism and the VS100 utilizes a 'positive latch' mechanism reducing unintended trips from vibrations or bumps for both designs

[Learn more >](#)

# Pressure Regulation and Precise Flow Control - Featured products

## Fisher™ 133, LSR, Tartarini™ M Large Direct-Operated Pressure Reducing Regulators



Direct-operated regulators ideal for industrial and commercial applications supplying gas to furnaces, burners and other appliances. A balancing system enables the regulator to control gas pressure accurately for maximum combustion efficiency despite varying inlet pressures.

- Wide pressure range capability
- Excellent shock characteristics and fast speed of response
- Bubble-tight shut-off, spring and diaphragm effects minimized
- LSR and M Series offer integrated slam-shut device

[Learn more >](#)



# Pressure Regulation and Precise Flow Control - Featured products

## Fisher™ Vee-Ball™ Valve with DVC6200 Digital Valve Controller and Fisher easy-e™ ET Globe Valve with C1 Valve Controller and easy-e Trim Cartridge



High performance, reliable and versatile control valve solutions for the majority of throttling valve applications with the reliable, effective Fisher Vee-Ball Valve. The dependable and reliable ET and easy-e Trim Cartridge combines repair 20 repair parts into 1.

- Fisher Vee-Ball control valve is the best choice in cost effective solutions
- The solid HD ball seal construction provides long service life in demanding applications
- Provides quick responsiveness to large step changes and precise control for small changes
- Fisher easy-e Trim Cartridge is a complete trim repair solution for minimizing downtime by 60%

[Learn more >](#)



# Pressure Regulation and Precise Flow Control - Featured products

## Bettis™ SCE300 Electric Actuator



Compact and lightweight intelligent all-in-one electric actuator for maintaining effective control of low-torque, quarter-turn valves and dampers.

- Highly configurable with variable speed and torque settings
- 35 to 2000 Nm output torque
- PROFIBUS and DeviceNet communications
- IECEX, IP66/68 or NEMA4/4X/6 certifications

[Learn more >](#)



# Pressure Regulation and Precise Flow Control - Featured products

## Fisher™ Commercial Service Pressure Reducing Regulators with Overpressure Protection

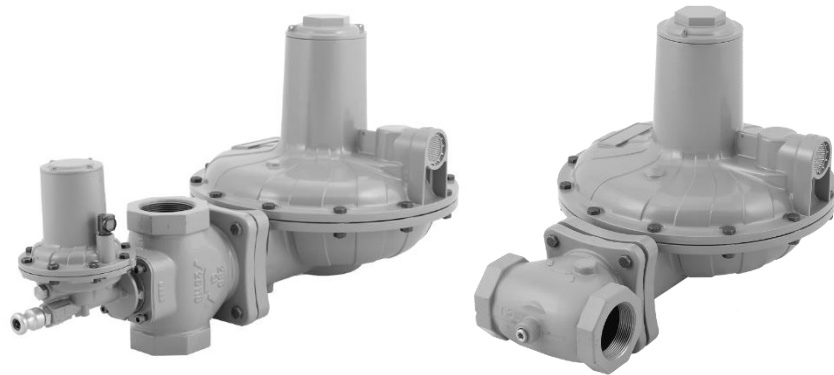

Direct-operated, pressure-reducing regulators provide safe and reliable solutions in a broad range of commercial and industrial applications.

- Type CS800 is highly configurable, fast-acting regulator that minimizes cost of ownership by providing a long service life and easy maintenance
- Flexibility provided by numerous body sizes and end connections, outlet pressure settings and orifice sizes
- Type CSB400 and CSB700 balance port design option allows for consistent downstream pressure independent of varying inlet pressure

[Type CS800 >](#)

[Type CSB400 >](#)

# Pressure Regulation and Precise Flow Control - Featured products

## Fisher™ Type 1098-EGR, EZL, 299H and 99 Pilot Operated Pressure Reducing Regulators

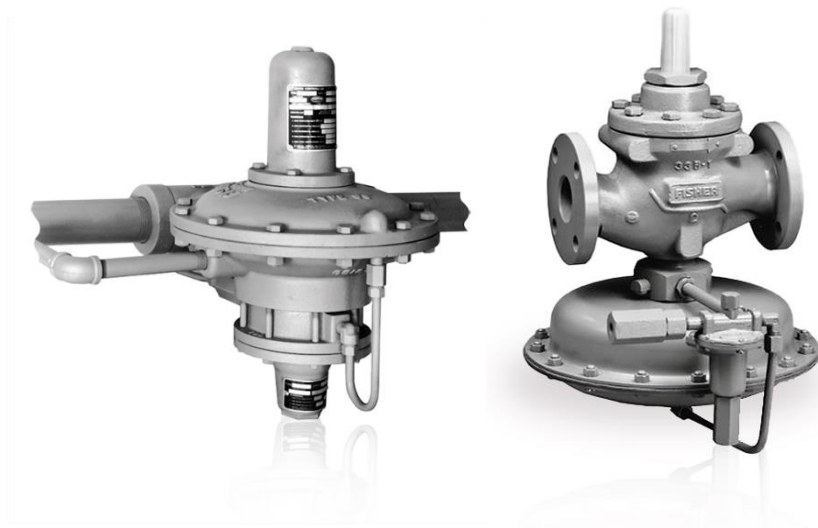

Fisher pilot-operated regulators provide economical and accurate pressure control in a wide variety of applications; fuel gas supply to industrial boilers, furnaces, ovens and mixers.

- Accurate control at pressure differentials as low as 1 psid / 70 mbar
- Stable and accurate downstream pressure control regardless of load changes or inlet pressure variations
- Whisper Trim™ Cage option reduces noise by up to 20 dBa
- Pilot-operated regs provide accurate pressure downstream across a wide range of flow demand
- Type 299HV and EZLOSX use a integral slam-shut device for over pressure protection

[Learn more >](#)

# Measurement, Instrumentation and Control Systems

Advanced measurement and instrumentation technology are the best way to reach the highest performances in term of energy efficiency and emissions control. This solutions is a must have to update a traditional linkage less air-fuel ratio control to a fully metered one. Modern measurement technologies can provide accurate feedback on the air-fuel ratio with best-in-class flow measurement of fuel, air, emissions levels, temperature, pressure and O2 content exhaust gas to ensure safety and superior energy performances. The DeltaV™ SIS process safety system has a uniquely scalable modular architecture that is based on the CHARMS Smart Logic Solver (CSLS) and the unprecedented flexibility and ease of use of the Emerson Electronic Marshalling solution. Each CSLS provides I/O processing, safety integrity level 3-capable logic solving and diagnostics in a single logic solver.

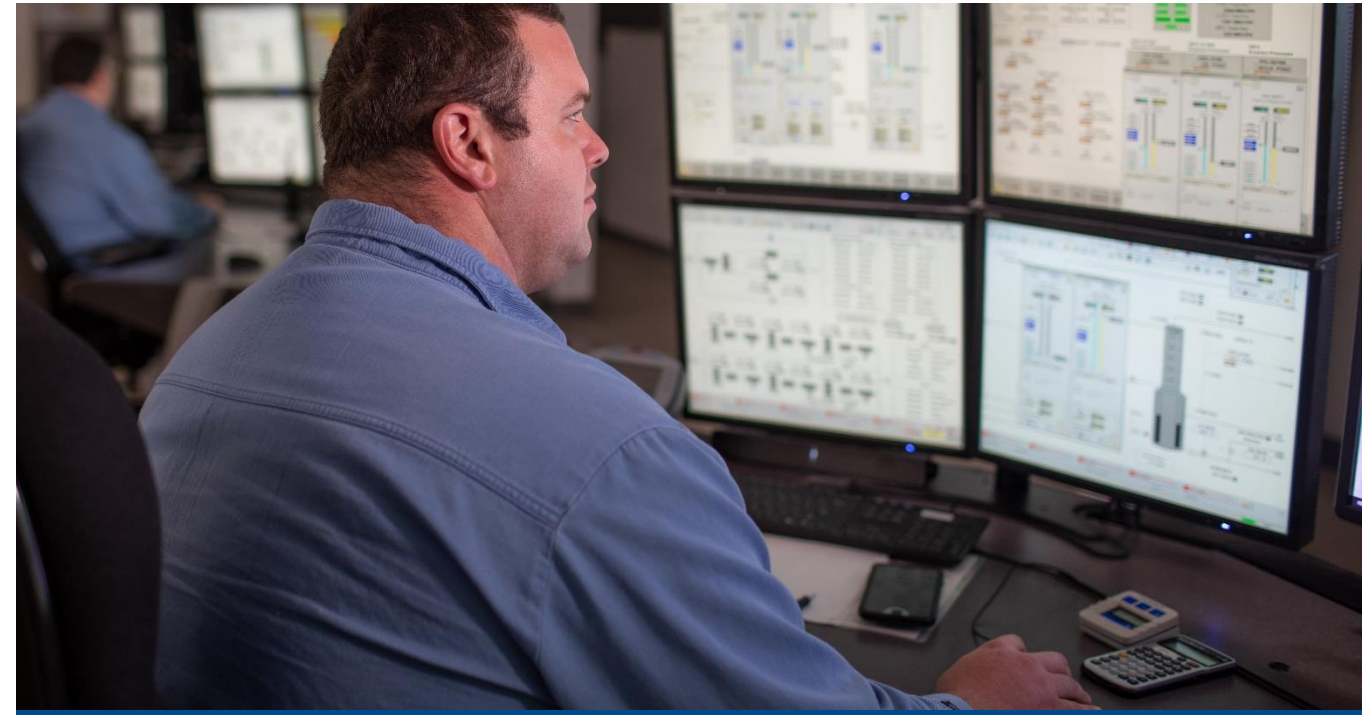

**What's your opportunity?**



**Services offered**



**Featured products**



# Measurement, Instrumentation and Control Systems - What's your opportunity?

- Reach top performances in term of energy efficiency and emissions control
- Move from linkage less air/fuel ratio control with position control to fully metered ratio control with direct feedback on key metrics
- Code Compliance DeltaV BMS solutions are designed and implemented in accordance with applicable safety codes for the process and the site location to deliver protection to the best degree possible metered ratio control with direct feedback on key metrics

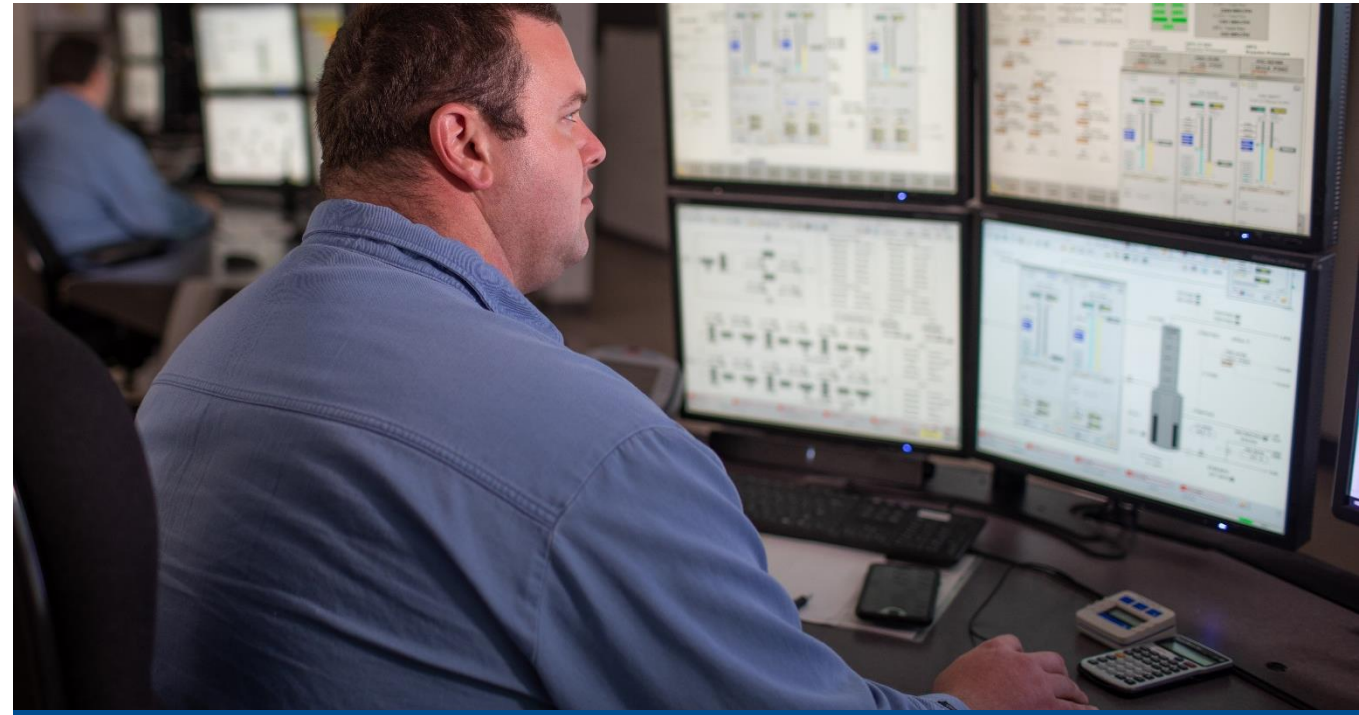

# Measurement, Instrumentation and Control Systems - Services offered

- Solving your toughest combustion system applications with a single solution for the entire fuel train
- Increased throughput and uptime with less maintenance
- Modernize and automate your applications for higher performance and efficiency

**Let Emerson help you optimize system performance, lower costs and keep your systems safe.**

When you build and ship your solutions all over the world, global approval helps simplify and streamline your manufacturing process. And fast delivery time is also essential. Whether your need a competitive total cost, high level of safety, or a single-source supplier Emerson can help—we're committed to the combustion category.

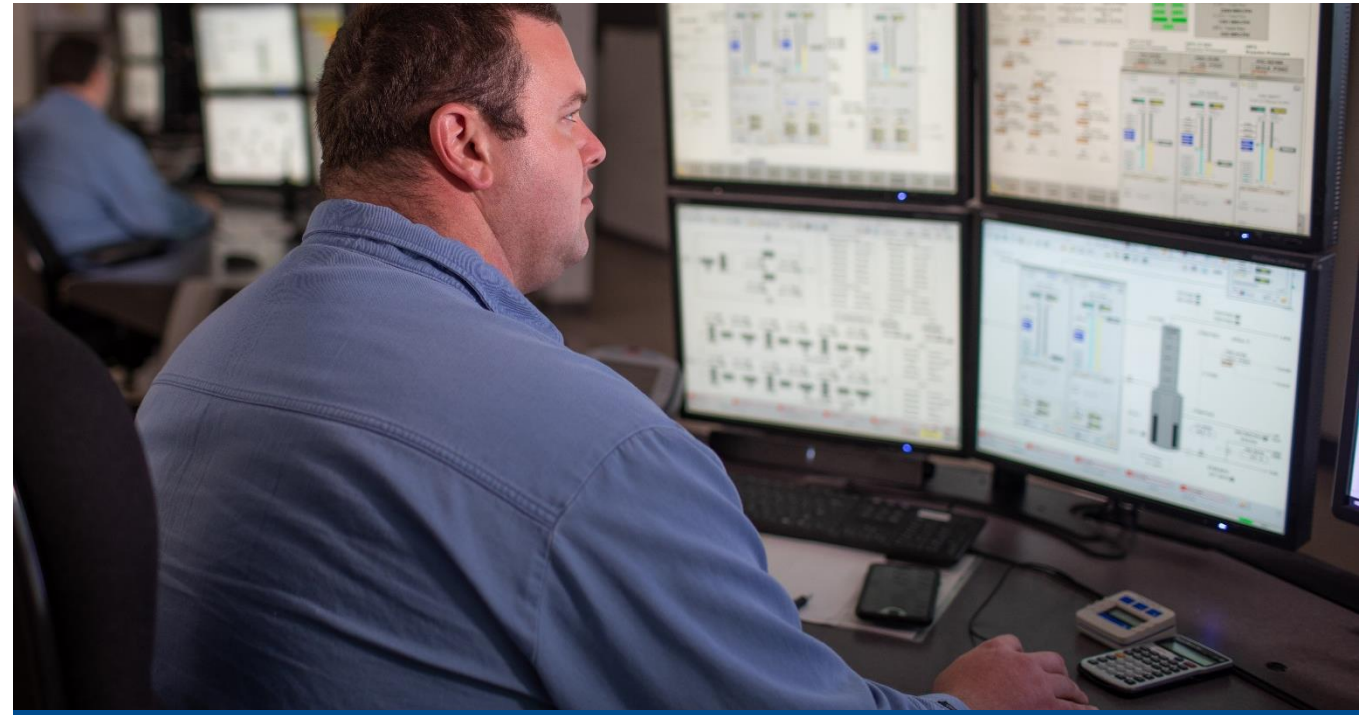

# Measurement, Instrumentation and Control Systems - Featured products



**BMS**



**Micro Motion™ F-Series**



**Rosemount™ OCX 8000  
Combustibles Transmitter**



**Rosemount 2051  
Pressure Transmitter / 644 Temperature**



**Rosemount Smart Pressure Gauge**

# Measurement, Instrumentation and Control Systems - Featured products

## BMS



- **Built for Compliance:** Especially designed to out-of-the-box comply with IEC61508 and IEC61511 standards, as well as other safety standards, such as NFPA 85, 86 and 87 and NFPA 72.
- **Optimized process reliability:** Research shows that more than 90% of all faults in SIS applications occur in field instruments and final elements. The DeltaV™ SIS process safety system has the world's first Smart Logic Solver using LS CHARMs. It communicates with intelligent field devices using the HART protocol to diagnose faults before they cause spurious trips. This approach increases process availability and reduces lifecycle costs.
- **Flexibility to meet project needs:** Each CHARMs Smart Logic Solver provides I/O processing, SIL 3-capable logic solving and diagnostics. This means that processing power is added as the system expands. Modularity also provides isolation of safety instrumented functions (SIF). This isolation eliminates single-points of failure for improved availability and safety integrity.

[Learn more >](#)

# Measurement, Instrumentation and Control Systems - Featured products

## Micro Motion™ F-Series



Delivering a highly reliable and robust measurement, coriolis flow meters are the preferred choice for process control applications.

- Achieve highly accurate mass volume flow and density measurement in applications that require a compact, drainable design
- Improve measurement and tracking with extensive process and meter diagnostics with on-board historian and data logging
- Gain real-time and in-process measurement integrity assurance with smart meter verification

[Learn more >](#)

# Measurement, Instrumentation and Control Systems - Featured products

## Rosemount™ OCX 8000 Combustibles Transmitter



Designed to provide industry-standard performance, the Rosemount 2051 Pressure Transmitter have easy installation, this DP flow transmitter can be pre-assembled to various primary elements.

This safety-certified transmitter also features a local operator interface (LOI) with easy-to-use menus and built-in configuration buttons for device commissioning without tools.

Engineered for versatility, the Rosemount 644 Temperature Transmitter is available with HART®, FOUNDATION™ Fieldbus or PROFIBUS® protocols in head or rail mount styles and a variety of enclosure options. By adding a Local Operator Interface (LOI), you can update your transmitter configuration in the field without tools.

[Learn more >](#)



## Rosemount™ 2051 Pressure Transmitter / 644 Temperature

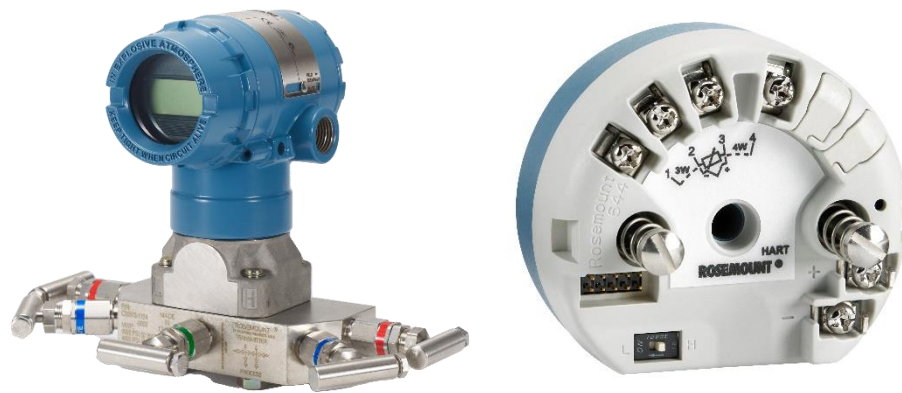

This rugged, compact unit has two of the world's most reliable and accurate sensors – the same high-performance oxygen sensor as the oxymitter while its unique combustibles detector has proven to be the most reliable on the market.

- Rugged sulfur resistant catalytic bead sensor
- Improved temperature control and heater design
- Vacuum fluorescent Local Operator Interface (LOI)
- LOI safety lock-out
- Improved sensor and sample block temperature stabilization

[Learn more >](#)

## Rosemount™ Smart Pressure Gauge

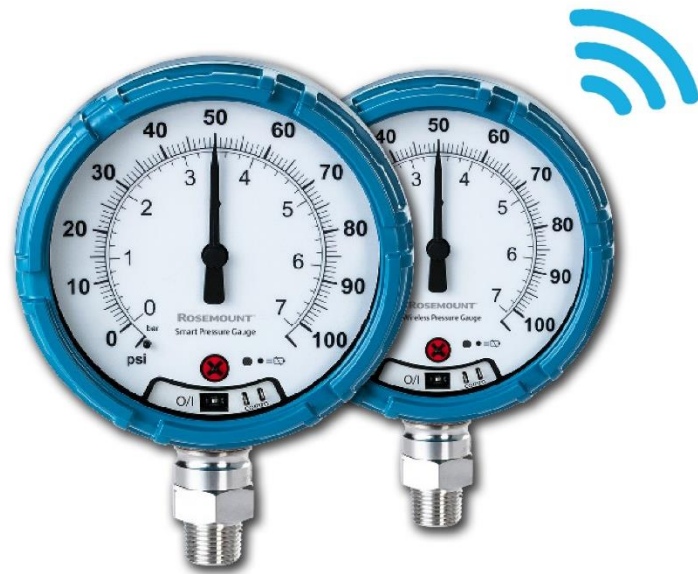

The Rosemount Smart Pressure Gauge features a robust design with industry-proven sensor technology to resist common traditional gauge failures. This pressure gauge provides up to 10 years of maintenance-free operation and replaces mechanical components for more reliable readings and a higher overpressure limit.

[Learn more >](#)

# Complete Fuel Train Solution for Industrial Burners

Fuel gas trains are assembled systems to control, measure, supply and cut the fuel gas to the burner. It ensures that the burner operates safely by reducing/monitoring gas pressure and cut the fuel supply to the burner in case of over pressure, under pressure or triggered safety interlock. Depending on the customer requirements, application type and local standards it can be composed by the following devices: filter, isolation valves, pressure regulator with integrated slam-shut valve, relief valve, pressure gauges, pressure transmitter, flow meter, volume corrector, flow control valve, automatic safety shut-off valves, pressure switches.

- Entire fuel train designed for application needs, comply with worldwide standards and certifications
- Plug and play solution

**What's your opportunity?**



**Services offered**



**Featured products**

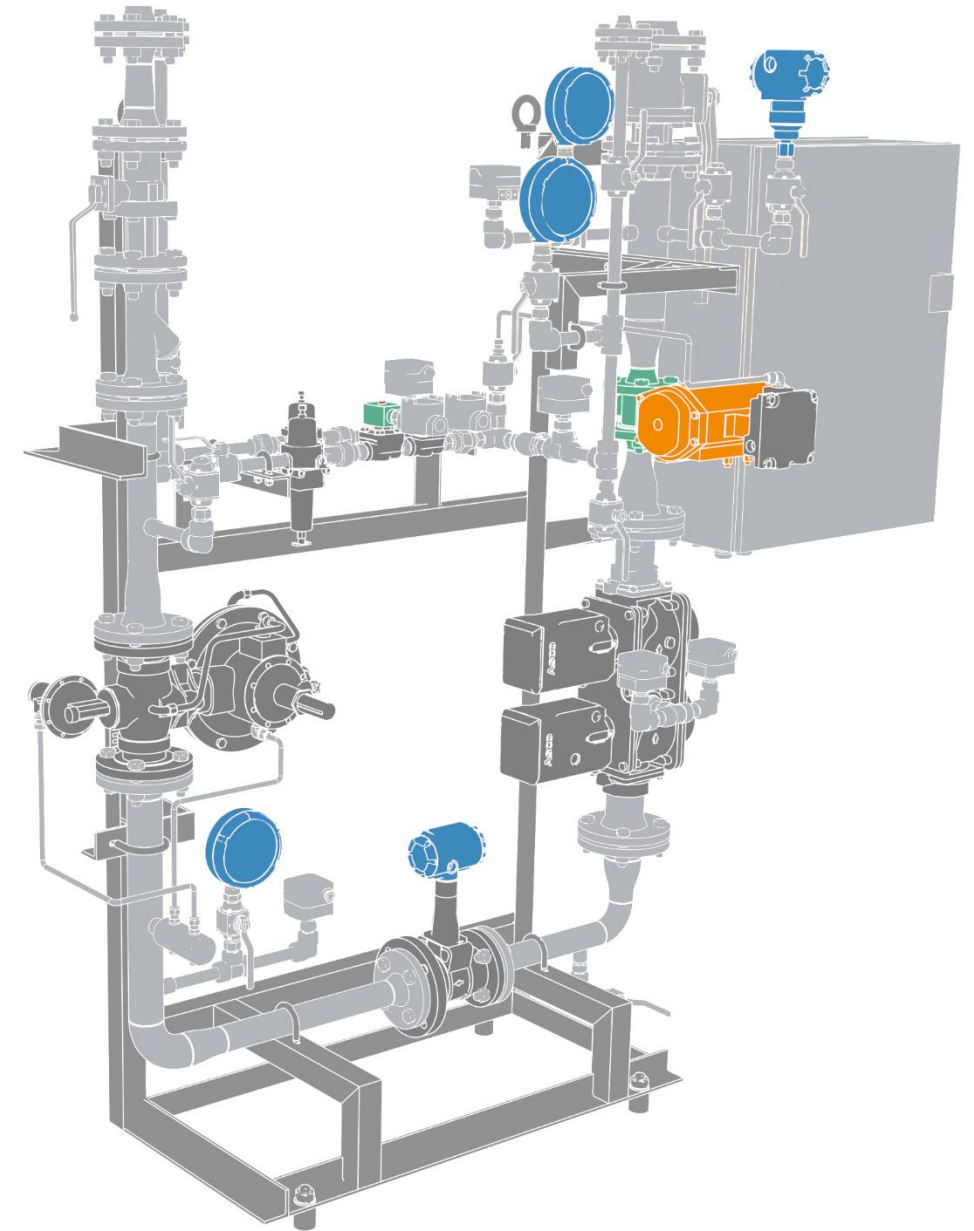

# Complete Fuel Train Solution for Industrial Burners - What's your opportunity?

Fuel gas trains are assembled systems to control, measure, supply and cut the fuel gas to the burner. It ensures that the burner operates safely by reducing/monitoring gas pressure and cut the fuel supply to the burner in case of over pressure, under pressure or triggered safety interlock. Depending on the customer requirements, application type and local standards it can be composed by the following devices: filter, isolation valves, pressure regulator with integrated slam-shut valve, relief valve, pressure gauges, pressure transmitter, flow meter, volume corrector, flow control valve, automatic safety shut-off valves, pressure switches.

- Entire fuel train designed for application needs, comply with worldwide standards and certifications
- Plug and play solution
- Single supplier for complete fuel train solution with know-how of main equipment
- Project management team to secure the project schedule, being one point of contact of entire solution

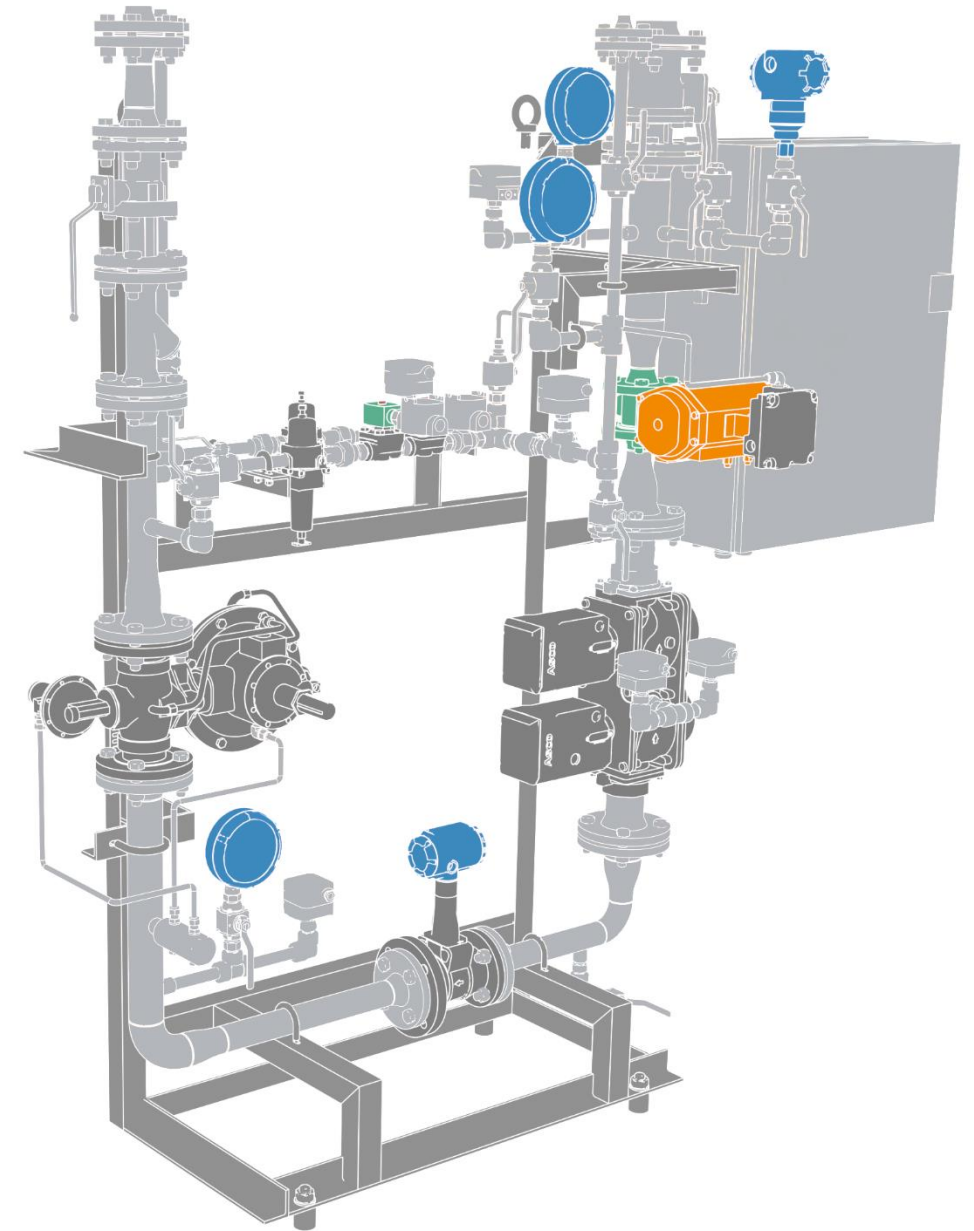

# Complete Fuel Train Solution for Industrial Burners - Services offered

Fuel gas trains are assembled systems to control, measure, supply and cut the fuel gas to the burner. It ensures that the burner operates safely by reducing/monitoring gas pressure and cut the fuel supply to the burner in case of over pressure, under pressure or triggered safety interlock. Depending on the customer requirements, application type and local standards it can be composed by the following devices: filter, isolation valves, pressure regulator with integrated slam-shut valve, relief valve, pressure gauges, pressure transmitter, flow meter, volume corrector, flow control valve, automatic safety shut-off valves, pressure switches.

- Entire fuel train designed for application needs, comply with worldwide standards and certifications
- Plug and play solution
- Solving your toughest combustion system applications with a single solution for the entire fuel train
- Increased throughput and uptime with less maintenance
- Modernize and automate your applications for higher performance and efficiency

**Let Emerson help you optimize system performance, lower costs and keep your systems safe.**

When you build and ship your solutions all over the world, global approval helps simplify and streamline your manufacturing process. And fast delivery time is also essential. Whether your need a competitive total cost, high level of safety, or a single-source supplier Emerson can help — we're committed to the combustion category.

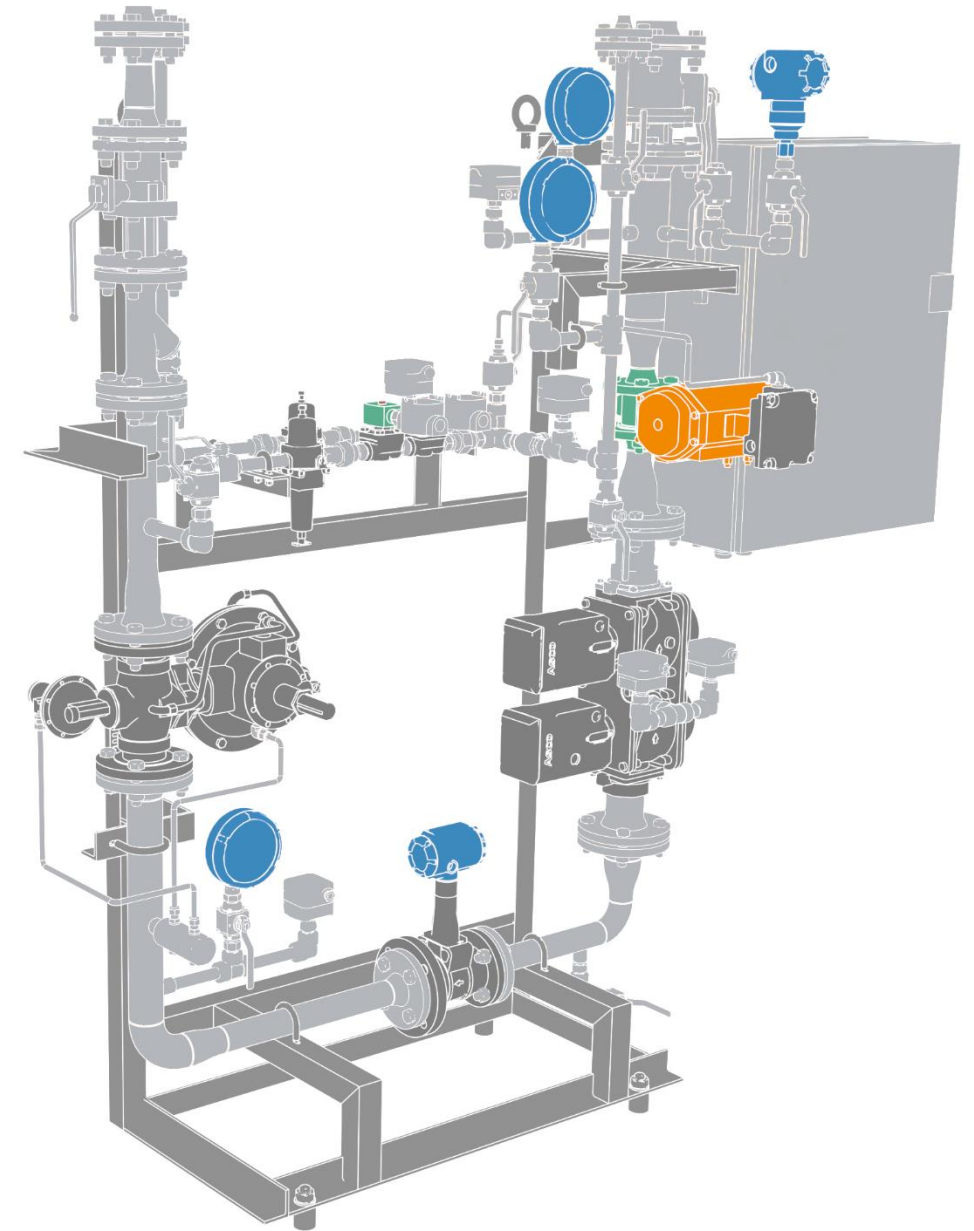

# Complete Fuel Train Solution for Industrial Burners - Featured products



- Reduce project complexity and respect deadlines thus complying to all applicable regulations and standards
- Ensure the use of the latest technology available
- Work directly with the product and technology experts
- Drop in place solution to help address ageing workforce and lack of specialized resources
- Optimizing supply chain

[Learn more >](#)

Fuel Train Solution



# Emerson can help you overcome your reliability issues with a complete industrial burner solution



**Burner-boiler**



**Catalytic reactors**



**Gas generators**



**Heat exchangers**



**HVAC equipment**



**Incinerators**



**Industrial furnaces**



**Kilns and ovens**



**Regenerative thermal oxidizer**



**Thermal fluid heaters**



# A complete offering backed by the global leader in gas train solutions

Emerson's combustion systems allow you to handle greater burner efficiencies and higher flows in a wider variety of applications and solutions, regardless of geographic location. Our combustion systems are comprised of the best products in combustion – ASCO™ valves, Bettis™ actuators, Fisher™ valves and regulators, DeltaV™ control systems, among others – with each solution focusing on innovation, safety, flexibility and reliability.

Our ASCO automation solutions help maximize your efficiencies, while optimizing your applications. Our Fisher products offer highly reliable flow control technologies so you can regulate and isolate your processes with certainty. And as part of Emerson's Plantweb™ digital ecosystem, our DeltaV solutions help automate your systems with a modern solution – providing decision integrity in all of your combustion applications.



▶ **Plan & Design**



▶ **Implement & Build**



▶ **Sales & Service Channels**



▶ **Education & Training**



# A complete offering backed by the global leader in gas train solutions

Emerson's combustion systems allow you to handle greater burner efficiencies and higher flows in a wider variety of applications and solutions, regardless of geographic location. Our combustion systems are comprised of the best products in combustion – ASCO™ valves, Bettis™ actuators, Fisher™ valves and regulators, DeltaV™ control systems, among others – with each solution focusing on innovation, safety, flexibility and reliability.

Our ASCO automation solutions help maximize your efficiencies, while optimizing your applications. Our Fisher products offer highly reliable flow control technologies so you can regulate and isolate your processes with certainty. And as part of Emerson's Plantweb™ digital ecosystem, our DeltaV solutions help automate your systems with a modern solution – providing decision integrity in all of your combustion applications.



## ▶ Plan & Design

- Producing with Certainty and Agility
- Online product & CAD configurators



## ▶ Implement & Build



## ▶ Sales & Service Channels



## ▶ Education & Training



# A complete offering backed by the global leader in gas train solutions

Emerson's combustion systems allow you to handle greater burner efficiencies and higher flows in a wider variety of applications and solutions, regardless of geographic location. Our combustion systems are comprised of the best products in combustion – ASCO™ valves, Bettis™ actuators, Fisher™ valves and regulators, DeltaV™ control systems, among others – with each solution focusing on innovation, safety, flexibility and reliability.

Our ASCO automation solutions help maximize your efficiencies, while optimizing your applications. Our Fisher products offer highly reliable flow control technologies so you can regulate and isolate your processes with certainty. And as part of Emerson's Plantweb™ digital ecosystem, our DeltaV solutions help automate your systems with a modern solution – providing decision integrity in all of your combustion applications.



## ▶ Plan & Design



## ▶ Implement & Build

- Application-specific expert consultations
- Ready-to-install customized packages



## ▶ Sales & Service Channels



## ▶ Education & Training



# A complete offering backed by the global leader in gas train solutions

Emerson's combustion systems allow you to handle greater burner efficiencies and higher flows in a wider variety of applications and solutions, regardless of geographic location. Our combustion systems are comprised of the best products in combustion – ASCO™ valves, Bettis™ actuators, Fisher™ valves and regulators, DeltaV™ control systems, among others – with each solution focusing on innovation, safety, flexibility and reliability.

Our ASCO automation solutions help maximize your efficiencies, while optimizing your applications. Our Fisher products offer highly reliable flow control technologies so you can regulate and isolate your processes with certainty. And as part of Emerson's Plantweb™ digital ecosystem, our DeltaV solutions help automate your systems with a modern solution – providing decision integrity in all of your combustion applications.



## ▶ Plan & Design



## ▶ Implement & Build



## ▶ Sales & Service Channels

- Extensive global channel network
- Technically-laden automation solutions experts



## ▶ Education & Training



# A complete offering backed by the global leader in gas train solutions

Emerson's combustion systems allow you to handle greater burner efficiencies and higher flows in a wider variety of applications and solutions, regardless of geographic location. Our combustion systems are comprised of the best products in combustion – ASCO™ valves, Bettis™ actuators, Fisher™ valves and regulators, DeltaV™ control systems, among others – with each solution focusing on innovation, safety, flexibility and reliability.

Our ASCO automation solutions help maximize your efficiencies, while optimizing your applications. Our Fisher products offer highly reliable flow control technologies so you can regulate and isolate your processes with certainty. And as part of Emerson's Plantweb™ digital ecosystem, our DeltaV solutions help automate your systems with a modern solution – providing decision integrity in all of your combustion applications.



▶ **Plan & Design**



▶ **Implement & Build**



▶ **Sales & Service Channels**



▶ **Education & Training**

- Educational courses for product and technology enhancements
- Learning and training centers for workforce improvement

